

ULTRASONIC INTELLIGENT SENSORS

ClampOn DSP Pig Detector

DIGITAL SIGNAL PROCESSING



ULTRASONIC INTELLIGENT SENSORS



ClampOn DSP Pig Detector

A Pig Detector is a tool that is always used in pigging operations. This operation is part of the operator's pipeline integrity management programme aimed at avoiding reduced capacity due to scale build-up or, in some cases, shut-down due to leakage, corrosion, erosion, etc. Pigging is also performed in some cases to separate changes of media being transported in a pipe.

The ClampOn DSP Pig Detector controls and monitors when the pig is passing the point of installation. Providing reliable information about the passage of the pig increases pipeline integrity and produces cost savings.

ClampOn pig detection systems perform this operation in a simple and safe way as they only monitor the pig from the outside of the pipe. The sensor is simply clamped onto the pipe, eliminating any need for welding or drilling during installation. There

ClampOn Ultrasonic Intelligent Sensor

- Non-invasive
- Digital Signal Processing (DSP)
- Complete digitalisation
- No analogue filters, circuits or amplifiers
- Two-way communication
- Real-time measurement
- Easy to relocate
- Contains no moving parts
- Can be mounted in hostile environments
- Incorporates sensitive, intelligent, intrinsically safe sensors
- Can be upgraded by software download
- Can store up to 60 days of measurement data within the sensor itself
- Self-testing capabilities
- Built-in temperature sensor and accelerometer (optional)
- User-friendly software for Windows™ 2000/2003/XP/NT4
- Versatile - one and the same sensor can perform particle detection, pig detection, spectrum analysis and more, all available in the software package of your choice.

is no need for inserts in the pig and the system is capable of detecting all types of pigs or plugs.

Principle of operation

The ClampOn DSP Pig Detector, based on our Ultrasonic Intelligent Sensor Technology, represents the latest state-of-the-art technology. This acoustic instrument accurately detects the passage of all types of pigs in real time, giving instant warning to the operator. Its signal output can also be used to indicate the amount of debris pushed ahead by the pig during pipeline cleaning operations. ClampOn pig detection systems have been successfully tested and used by a large number of clients for many years, and this latest model makes the system even more compact and reliable. DSP (Digital Signal Processing) represents leading-edge technology in this field and keeps us ahead of the competition.

Digital Signal Processing

The ClampOn DSP Detector, available in topside and subsea versions, is a more compact and user-friendly unit than other instruments on the market. It is easier to install in the field and easier to move to other locations.

DSP involves complete digitalization of the system and the elimination of analogue filters. This technology is increasingly used in a wide range of "smart electronic devices" as it provides sufficient capacity to perform advanced signal-processing tasks in real time. Such devices include medical diagnostic instruments, radar and sonar systems and mobile phones. ClampOn is the only manufacturer of pig detection systems to use DSP, which enables the sensor to operate in several frequency ranges simultaneously, eliminating the danger of the detector being triggered by noise sources other than pigs.

The sensor

The sensor unit is made of stainless steel for topside units and titanium for subsea units, and is clamped to the outer surface of the pipe through which the pig is passing. The topside units are certified according to EEx ia IIB, or EEx d IIC. All sensors can be operated at pipe-wall temperatures ranging from -40 to +200°C. An unlimited number of sensors can be connected to a single computer for real-time measurements. The sensors transmit an ASCII signal to the control computer.

Computer

The signal from the sensors can be interfaced directly with any type of Main Control System. If a dedicated computer is required, ClampOn can supply a PC equipped with our specialized software running on the Microsoft Windows™ Operating System. The computer is installed in a safe area and enables the operator to detect the passage of pigs in real time, as well as generating reports from one or more sensors.

Field lamp / Reset button

The topside sensors can also be supplied with an indicator lamp that lights up when the pig has passed as well as a button to reset the sensor.

Cabling

All cables can be supplied and terminated by ClampOn, with or without quick connector, or supplied by client.



CLAMPON

Ultrasonic Intelligent Sensor

**CLAMPON DSP
PIG DETECTOR**



System layout

Field Area

EEx ia IIB

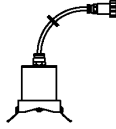

EEx ia IIB
Light/reset



EEx d IIC

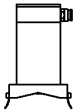

EEx d IIC
Light/reset

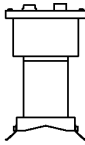

Safe area

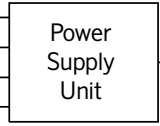

ClampOn
Computer

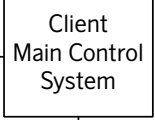

TCP/IP
Client
Network

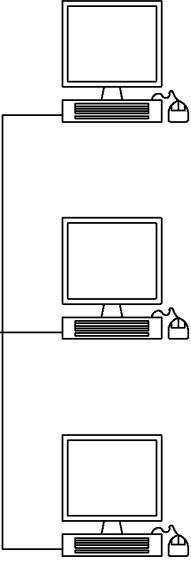

Subsea

Compact

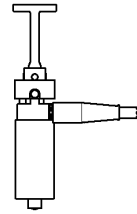

Deepwater

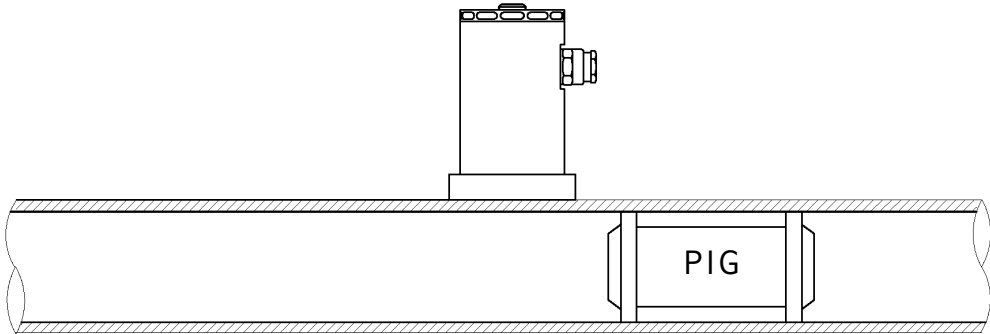
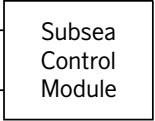
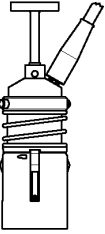

Signal Output Options

- RS485
- 4-20mA
- RELAY

PRODUCT SPECIFICATIONS

PIG DETECTOR

Principle of operation	Passive acoustics, intelligent sensor
Type of pig	All types
Minimum Pig Speed	0.03 meter per second
Method of installation	Clamped to pipe surface, non-intrusive
Sensor electronics	Intelligent DSP electronics with signal processing
Interface options	All sensors can be supplied with: Digital RS485 (ASCII, binary, ModBus RTU), 4-20mA (active/passive), Relay, reset. Options for ATEX approved sensors: local light/reset Options for subsea: CANBus, Profibus Other functions available: Vibration monitoring, sensor self test
Two-way communication	Yes
Software upgrading	Yes
Pipe Surface Temperature	-40 to 225 °C (-40 to 392 °F)
High temperature fixture	500 °C (-932 °F)
Flow regimes	Oil, gas, water, multiphase
Diagnostic features	Self test, vibration, 0,25Hz – 1000 Hz ±5G

COMPUTER

Minimum hardware	Pentium III (or equivalent!) with 512 MB RAM
Software requirements for ClampOn's software	Windows™ 2000/2003/ XP/NT 4
Input	Serial, Modbus, ethernet, OPC
Signal output	Serial, Modbus, ethernet, 4-20mA, Relay, Client Server

SAFE AREA EQUIPMENT

Mains power supply	12 – 48 VDC or 100-260 VAC 50-60 Hz
Power Consumption	Max 2,1 W per detector + computer rack module

TOPSIDE PIG DETECTOR

Intrinsically Safe (IS) Approval	
Inmetro	BR-Ex ia IIB T2-T5, Zone 0 BR-Ex d/de IIB T5, Zone 1
ATEX	EEx ia IIB T2-T5 II1G Zone 0 EEx d/de IIC T5 II2G Zone 1
CSA C&US	Ex ia IIB T5, Class I Division 1 Group C,D, Zone 0
GOST-R / GG TN-K	2Ex de IIC T5, IP66, Zone 1
Ingress protection	EExia: IP68, EExia with light/reset IP67, EExde IP68, EExde with light/reset IP66

SUBSEA PIG DETECTOR

	COMPACT	DEEPWATER
Water depth	2500m	4500m
Max. operating pressure barA	250 (3625psi)	450 (6526psi)
Max. test pressure barA	300 (4351psi)	675 (9790psi)
Housing material	Titanium	Titanium
Dimensions excl. ROV handle	ø90 x 324mm (ø3.5" x 12.8")	ø150 x 359mm (ø5.9" x 14.1")
Dry weight, kg (lbs)	5.2 (11.5)	15.0 (33.1)
Hose/jumper interface	Bennex or ODI	Bennex or ODI
Independent redundant electronics/ single electronic	Yes	Yes
Gasket / sealing	No	No
EB welding	Yes	Yes
Glass-metal penetrator	Yes	Yes
Low pressure / high pressure chamber	Yes	Yes
ROV installation/retrieval	Yes	Yes
Retrofit clamp/funnel	Yes	No
Power Supply	12-28VDC	12-28VDC
Current draw	Approx. 56mA @ 24VDC	Approx. 56mA @ 24VDC
Design Lifetime (MTBF)	220 000 hours (25 years)	220 000 hours (25 years)

ClampOn - the leader in sand, pig and corrosion-erosion monitoring

ClampOn has since the beginning in 1994 grown to be the largest supplier of passive ultrasonic systems for sand/particle monitoring to the international oil and gas sector. All products supplied by ClampOn, particle monitor, pig detector, corrosion-erosion monitor and leak monitor are based on the same, well proven technology platform. Both the topside and the subsea instruments incorporate Digital Signal Processing (DSP), complete digitalization eliminating analogue filters, circuits and amplifiers.



The ClampOn Ultrasonic Intelligent Sensor processes all data in the sensor itself (patented principle), thus enabling the instrument to discriminate between sand-generated and flow-generated noise. This is of importance to the user since changes in flow rates and the gas/oil ratio will not affect the performance of the system.

A good signal to noise (s/n) ratio is vital for quality measurements of this sort, and ClampOn's sensors are the very best in this respect. With the new version, the external noise has been completely eliminated.

The sensors has memory capacity for storing up to 60 days of data, and can even be reprogrammed between being a sand monitor, a pig detector or a corrosion-erosion monitor for monitoring of changes in wall thickness.

Subsea Sensors

The subsea sensors were developed in close collaboration with Shell Deepwater Development Inc. in Houston and FMC Energy

Systems in Norway. The successful outcome of the project was a sand monitoring system that combined an extremely long working life with excellent acoustic properties, offering reliability in the high pressure deep-water environment. ClampOn has since 1998 supplied approximately 500 subsea sensors to the oil and gas industry. The subsea meters have been under a continuous development in order to optimize quality and performance, and to meet the requirements in the market.

ClampOn DSP Corrosion-Erosion Monitor (CEM)

The CEM is monitoring any changes in wall thickness. Two to eight transducers are glued onto the surface of the pipe (or other metal plate structure) and connected to a clamp-on control unit. The control unit will continuously send and receive guided waves between the transducers, resulting in a network of measurement paths that cover the selected area.

The working principle of the instrument is based on transmitting ultrasonic signals that propagate through the pipe material. The transmitted signal is received by a sensor and is analyzed using advanced data processing schemes.

ClampOn DSP-06 Particle Monitor

All sensors are exactly alike and interchangeable, an advantage if sensors should be moved/relocated or in case of service. The DSP's increase in processing capacity enables the sensor to combine signals from several frequency ranges when analysing the flow. The ClampOn sensors are versatile, and are the only instruments on the market offering two-way communication between sensor and control system. This solution enables future upgrade of the sensor by a simple download of new software. When using digital output from the sensors, they can be installed in a "multi-drop" system.



ISO 9001 CERTIFIED COMPANY

ULTRASONIC INTELLIGENT SENSORS

NORWAY: ClampOn AS, Damsgaardsvn. 131, N-5162 Laksevaag, Bergen, Norway, Phone: +47 5594 8850, Fax: +47 5594 8855, e-mail: mail@clampon.com - USA: ClampOn, Inc., 15720 Park Row, Ste. 300 (77084), PO Box 219206 (77218-9206), Houston, TX, USA, Phone: +1 281 492 9805, Fax: +1 281 492 9810, e-mail: info@clamponinc.com - WEB: www.clampon.com